

MINIMAN-75

EXTRACTION ARM

The MiniMan-75 is a compact flexible arm, which is ideal for all types of smaller dust and fume applications.

The arm is fitted with exterior friction joints. The inner tubes are kept in place by a gas spring (standing arm) or a balancing strap (hanging arm). This design ensures smooth movement of the arm.

The MiniMan-75 arm is available in different versions. The specific TopGrade arms have a distinctive colour and are meant for use in clean working environments, such as laboratories.



MiniMan type
MM-75-1.0/S

MiniMan type
MM-75-1.0/H

APPLICATIONS

The standard MiniMan-75 arm (yellow) is intended to be used for the following applications:

- soldering fumes
- airborne dust
- fumes from solvents

The MiniMan-75 TopGrade arm (fully white) is especially suitable for use in laboratories in the pharmaceutical, chemical and food processing industry.

SPECIFICATIONS

■ Physical dimensions and properties							
Diameter	Ø 75 mm (3 in.)						
Material:	<ul style="list-style-type: none"> • tubes • hoses 						
Colour:	<table border="0"> <tr> <td>standard arm</td> <td>TopGrade</td> </tr> <tr> <td>• yellow RAL 1004</td> <td>• white RAL 9010</td> </tr> <tr> <td>• black</td> <td>• white</td> </tr> </table>	standard arm	TopGrade	• yellow RAL 1004	• white RAL 9010	• black	• white
standard arm	TopGrade						
• yellow RAL 1004	• white RAL 9010						
• black	• white						
■ Performance							
Recommended airflow	100-250 m ³ /h (59-147 CFM)						
• min. airflow	• 100 m ³ /h (59 CFM)						
■ Conditions of storage and use							
Process temperature:	<ul style="list-style-type: none"> • min. 5°C (41°F) • nom. 20°C (68°F) • max. 70°C (158°F) 						
Max. relative humidity	90%						
Suitable for outdoor use	no						
Storage conditions	<ul style="list-style-type: none"> • 5-45°C (41-113°F) • relative humidity max. 80% 						
■ Options and accessories							
DAMPER-75	sealed shut-off valve						
MM-001/B	round extraction hood Ø 150 mm (5 7/8 in.)						
MM-004	transparent dome hood Ø 385 mm (15 1/8 in.)						
MM-005	table bracket (only for MiniMan S types)						

■ Product combinations	
PA-110/160 PA-220/160	stanchion + ducting
Extraction fan:	suitable for:
• FUA-1800	• 3-4 MiniMan arms
• FUA-2100	• 5-6 MiniMan arms
• FUA-3000	• 9-10 MiniMan arms
• FUA-4700	• 15-16 MiniMan arms
■ Scope of supply	
Extraction arm, incl. mounting bracket (fully assembled)	
■ Order information	
Number/package	1
■ Logistics data	
Packing dimensions	1100 x 300 x 200 mm (43 1/4 x 11 3/4 x 7 7/8 in.)
Max. number/pallet	10
Harmonized Tariff Code	84219990

WORKING REACH

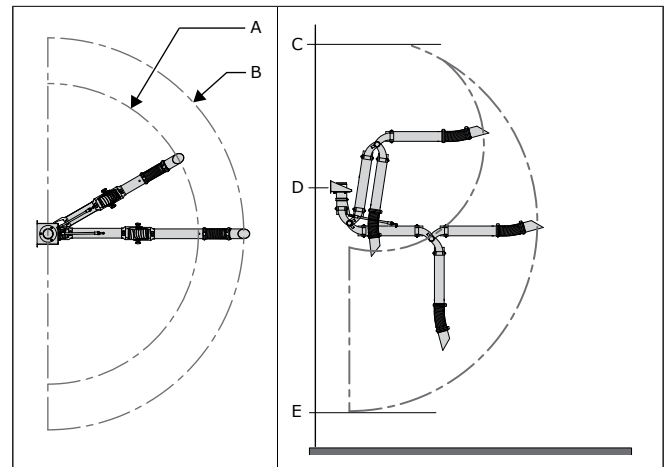

	MM-75-1.0/H		MM-75-1.5/H		
	mm	inch	mm	inch	
A	1160	46			Height from the floor
B			1512	60	
C	2250	89	2500	98	
D	1500	59	1500	59	
E	750	30	250	10	

Remaining specifications

Type	MM-75-1.0/H	MM-75-1.5/H	MM-75-1.0/S	MM-75-1.5/S
■ Physical dimensions and properties				
Mounting position	hanging	hanging	standing	standing
Length (nom.)	1 m (3 ft)	1,5 m (5 ft)	1 m (3 ft)	1,5 m (5 ft)
Weight (net)	4 kg (9 lbs.)	4,5 kg (10 lbs.)	4 kg (9 lbs.)	4,5 kg (10 lbs.)
■ Order information				
Article no.:				
• yellow arm	0000101100	0000101104	0000101102	0000101106
• white arm (TopGrade)	0000101112	0000101114	0000101113	0000101115
■ Logistics data				
Gross weight	4,5 kg (10 lbs.)	5 kg (11 lbs.)	4,5 kg (10 lbs.)	5 kg (11 lbs.)

MOUNTING EXAMPLES "H" TYPES

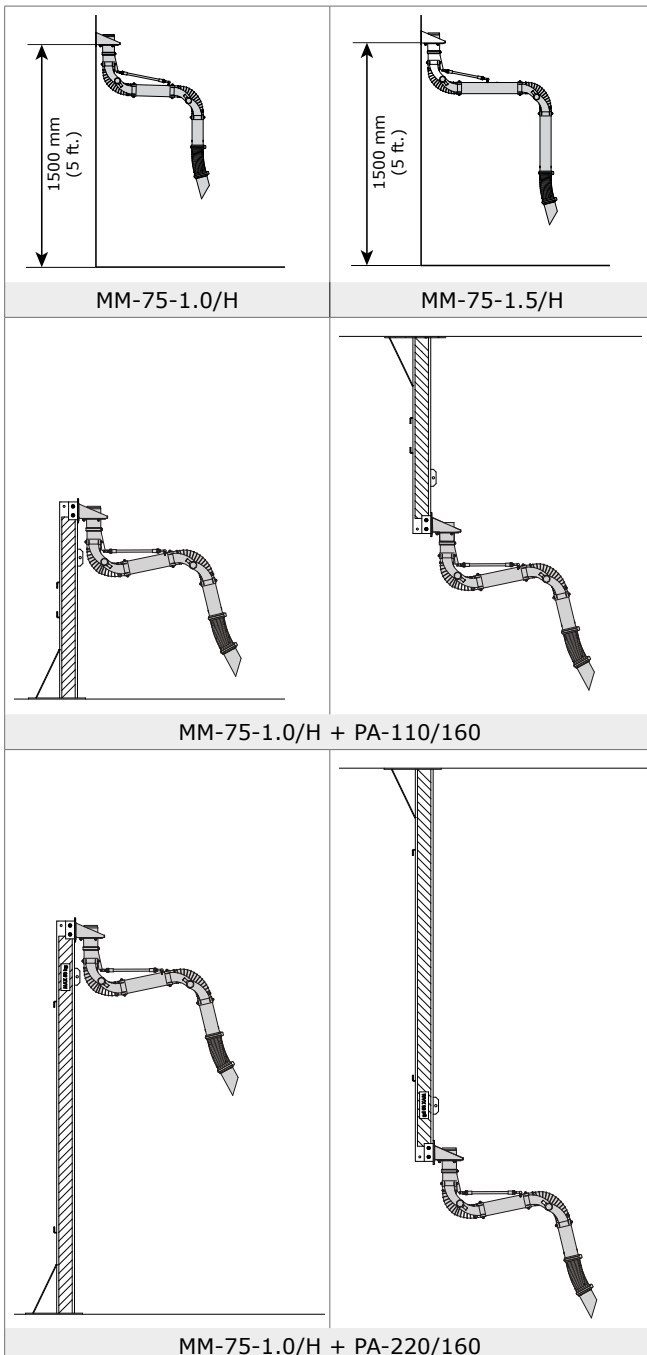

MOUNTING EXAMPLES "S" TYPES

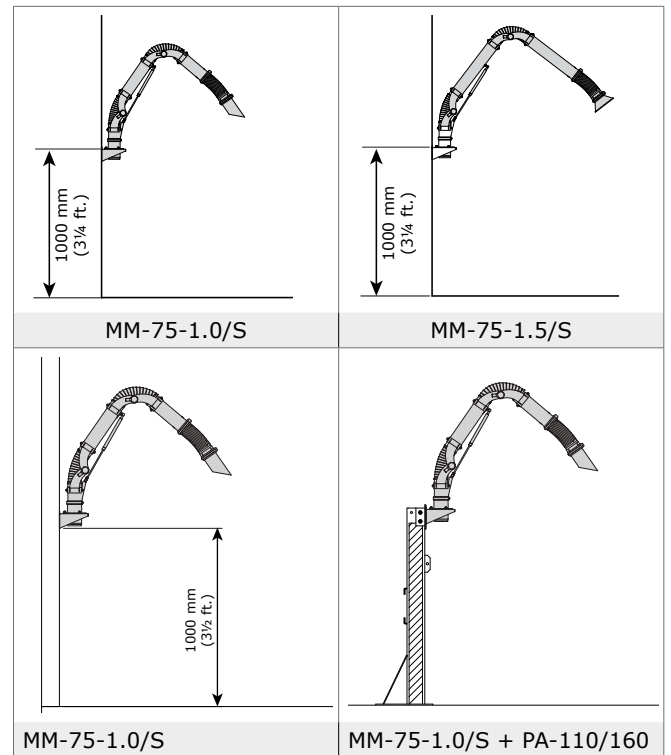

PRESSURE DROP

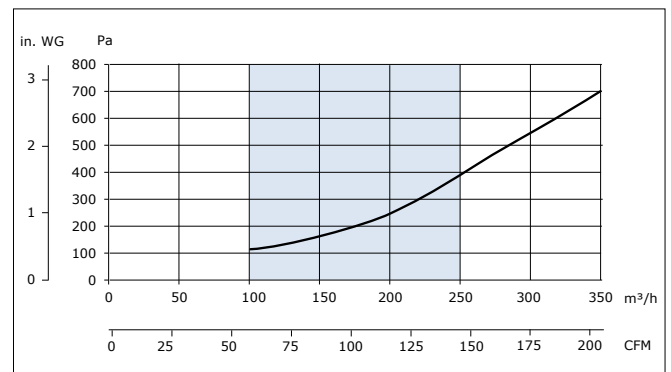

FEATURES & BENEFITS



Exterior friction joints ("ClearThru" design), which allows for maximum air velocity, low pressure drop and low noise level



Semi-rigid hose with nozzle



Special TopGrade version for clean working environments

Application restrictions

Do **not** use the product in combination with a filter for the following applications or in the following circumstances: polishing applications in combination with grinding, welding or any other application that generate sparks (fibres from polishing or abrasive flap disks are highly flammable and pose a high risk of filter fires when exposed to sparks) | aluminium laser cutting | oil mist | heavy oil mist in welding fume | arc-air gouging | extraction of aggressive fumes and gases (e.g. from acids, from alkaline, from soldering paste containing lithium) | extraction of hot gases (more than 70°C/158°F continuously) | grinding aluminum and magnesium | flame spraying | extraction of cement, saw dust, wood dust etc. | sucking cigarettes, cigars, oiled tissues and other burning particles, objects and acids | explosive environments or explosive substances/gases



Product type
Article no.
Product category
Version

MiniMan-75
refer to Order information
extraction arms
201222/B

Always check the latest version on www.plymovent.com